

FS 110/111/115/120

Calorimetric flow switch

It is a device that monitors the flow of fluid based on calorimetry principle. If the flow rate drops below a limit set by user, the status output is changed. The flow rate is displayed by ten LEDs and it is possible to select a boundary for contact making/breaking in the same graduation. The measuring cycle takes from 4 sec to 8 sec with the recommended measurement range 4...150 cm/sec. Based on DN piping, the bar sensor is available in three lengths, 65 mm (standard), 125 mm and 175 mm. In case of an empty pipeline, the sensor behaves in the same way as with zero flow.

The flow switch is made in four versions as follows:

- FS 110 – 1× status output
(depending on flow velocity)
- FS 111 – 2× status output
(depending on flow velocity)
- FS 115 – 2× status output
(1× depending on flow velocity and 1× on temperature)
- FS 120 – 1× status output and 1× current output
(depending on flow velocity)

Flow Switch meets the requirements of DNV international regulations for certification in the maritime shipping and industrial sectors.

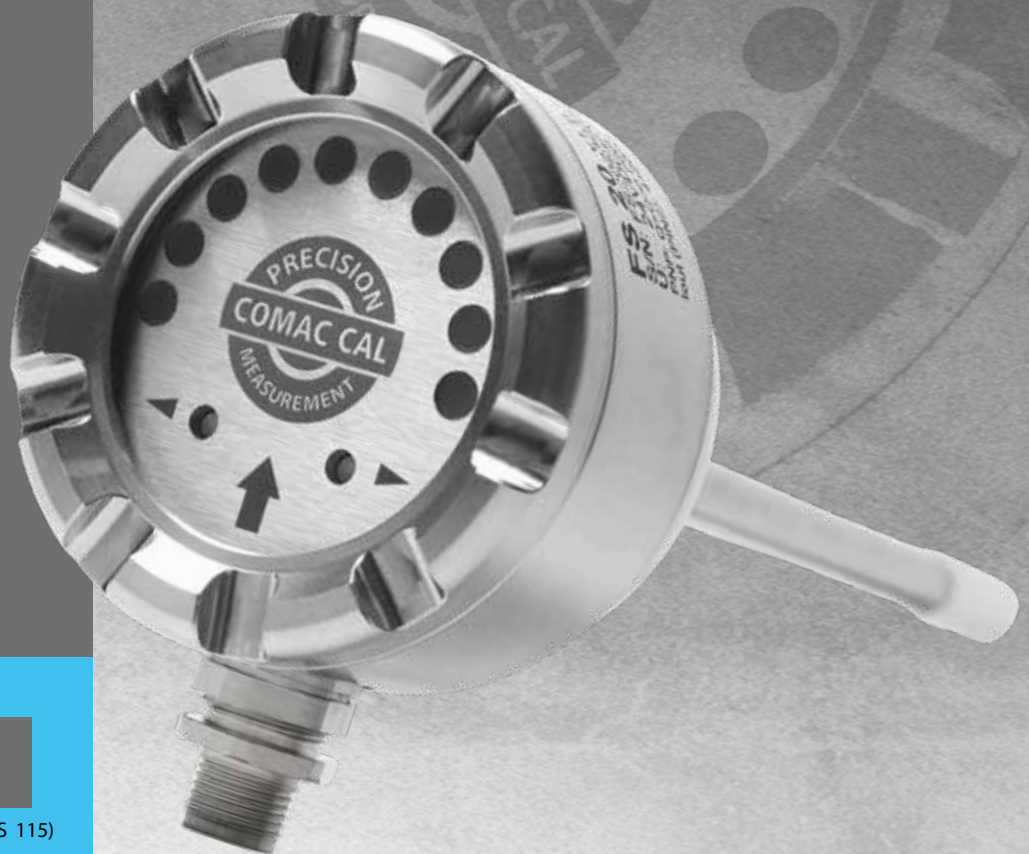

MAIN BENEFITS

- possibility to use another status output (version FS 115) for monitoring of temperature according to setting
- for FS 120 design, in addition to a closing contact also 4...20 mA current output
- 10 LEDs to display the current flow and adjusted switching limits
- „self teaching“ system with an option to set Q_{min} and Q_{max}
- possibility of setting the switching limits (insensitivity band preset)
- electrical connection by means of M12, 4-pin connector
- continuous control of the sensor for correct operation
- full stainless construction
- DNV certificated



COMAC CAL

TECHNICAL DATA

Power supply	24 V ± 10 % DC with polarity reversal protection (other upon request)
Input power	1.5/4 VA
Electrical connection	M12 × 1, 4 pin connector
Process connection	according to DIN2353, with the M16 × 1.5 union nut through the 24° ring into the direct socket with pipe thread (G1/2"; G1/4"; M14 × 1.5; NPT1/4")
Design	compact, remote
Display	10× three-colour LED (flow velocity) 1× LED (temperature – for FS 115 only)
Output types	relay (for FS 110 only), PNP, NPN, 4...20 mA (for FS 120 only)
Contact rating	130 mA / 60 V / 500 mW
Response time*	1...6 sec
Velocity flow range	4...400 cm/sec
Accuracy	±2... ±8 cm/sec
Hysteresis	2...8 cm/sec
Controls	2× flush-type push button
Medium temperature	-10...+80 °C
Ambient temperature	-20...+55 °C
Material in contact with media	stainless steel 1.4404 (for applications in seawater, 1.4410 can be used)
Maximum pressure	63 bar
Degree of protection	IP66, IP68
Ambient humidity	max. 90 %
Size (H×W×D)	110×84×70 mm (in case of longer version of bar sensor, the overall height will also increase)
Weight	666 g
Status contact	SSR, passive, potential-free, max. 350 V AC/DC, 150 mA, 400 mW

* for water (25 °C)

METER STATES DISPLAYED



first LED flashing
the flow below the monitor
range



last LED flashing
the flow above the monitor
range



the flow velocity
is within the adjusted monitor
range

4–20 mA CURRENT OUTPUT (FS 120 ONLY)

The meter is shipped by the manufacturer with the 4–20 mA output set in such a manner that the zero velocity flow of the media corresponds to the output of 4 mA whereas the velocity of 4 m/sec corresponds to 20 mA. The dependence of current on velocity is not linear.

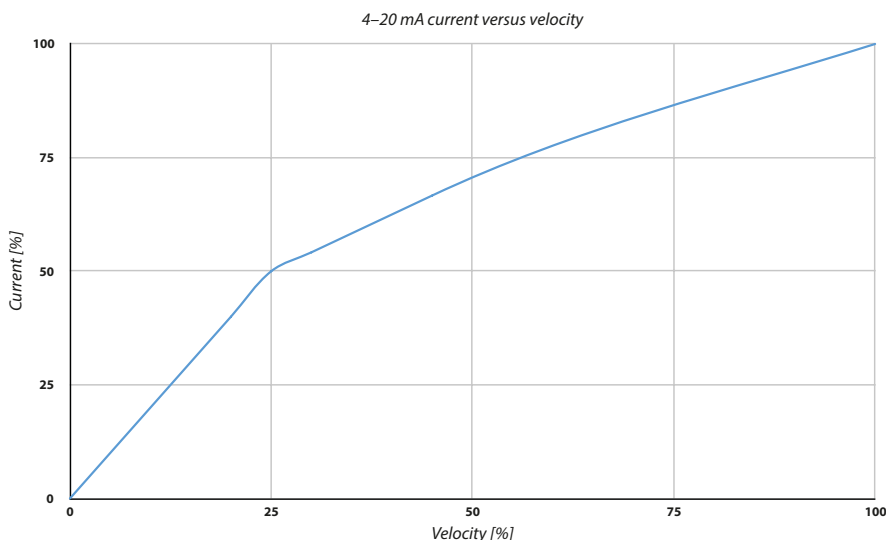

LED INDICATION

The flow switch point on LED scale can be implemented using two colours (red LED or amber LED), indicating at the same time which contact is normally closed or normally open.

In case of FS115, the temperature switch point is indicated by the LED located between the control push buttons. If the temperature of media is above/below the set-point, the LED is red, indicating that PIN2 is open at the same time (the sensor supplied as standard is configured open at a temperature above the set limit with the LED turned ON). If the logic of the normally open/normally closed point is changed by the user, the logic of both outputs is changed at the same time (applicable to FS 111 and FS115 versions).

Display	LED	Flow velocity in % of set Q_{max}
Flashing	LED 1	below 2 %
Luminous	LED 1	2–5 %
Luminous	LED 2	5–10 %
Luminous	LED 3	10–15 %
Luminous	LED 4	15–20 %
Luminous	LED 5	20–25 %
Luminous	LED 6	25–35 %
Luminous	LED 7	35–47.5 %
Luminous	LED 8	47.5–62.5 %
Luminous	LED 9	62.5–80 %
Luminous	LED 10	80–100 %
Flashing	LED 10	above 100 %

BASIC DIMENSIONS

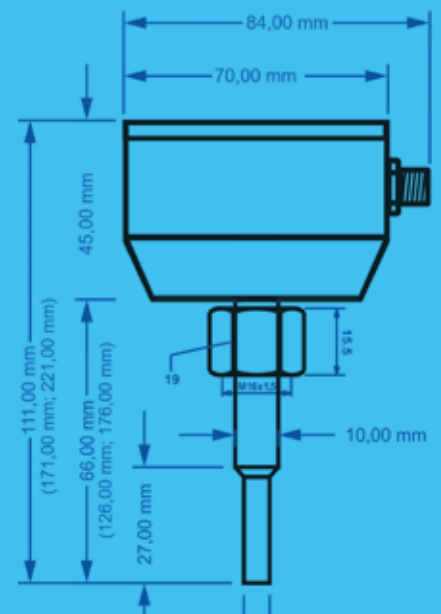

FS 110/111/115/120

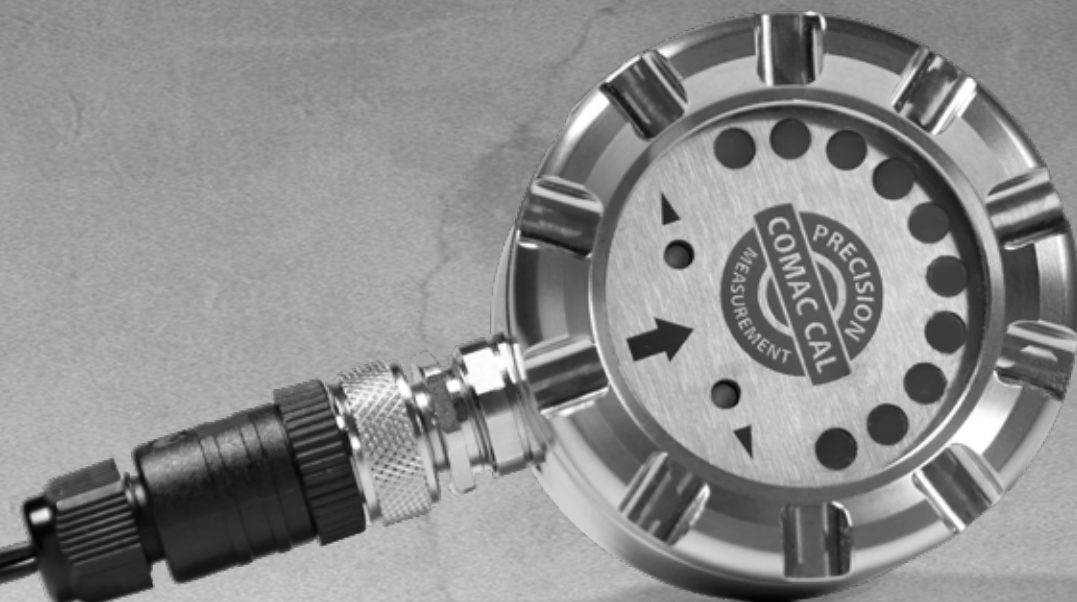

In case when it is necessary to monitor the medium flow in the pipe with a smaller DN than DN 25 (or the flow velocity is below the sensor range at the pipe diameter given), it is possible to use an adapter block with a corresponding flow velocity and ensure correct operation and keep the installation conditions in this way.

The adapters are designed for a short version of the **65 mm** sensor by using a direct neck with **G $\frac{1}{2}$ "** pipe thread.



ADAPTER BLOCK

INDIVIDUAL DESIGNS

- FS adapter block DN20/G3/4" for 1 ... 10 l/min. (size 150x50x40 mm)
- FS adapter block DN15/G1/2" for 0,5 ... 5 l/min. (size 150x50x30 mm)
- FS adapter block DN10/G1/4" for 0,2 ... 2 l/min. (size 150x50x30 mm)
- FS adapter block DN4.5/G1/4" for 50 ... 500 ml/min. (size 70x50x30 mm)
- FS adapter block DN2.7/G1/4" for 15 ... 150 ml/min. (size 70x50x30 mm)

Sensor control

The flow switch has two flush-type control buttons, making it possible

- the switching point/points for flow velocity (temperature in some case)
- to change the logic of the N.O./N.C. output
- to calibrate the minimum and maximum flow values of the monitoring device
- to reset the original parameters from factory



WIRING CONNECTION

FS 110 – Relé

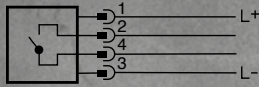

FS 110 – PNP

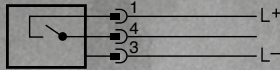

FS 110 – NPN

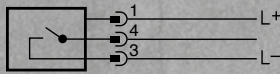

FS 110

RELAY

- PIN 1 – Supply voltage +24 V
- PIN 2 – Relay contact switch point
- PIN 3 – Supply voltage GND
- PIN 4 – Relay contact switch point

FS 111 / FS 115 – PNP

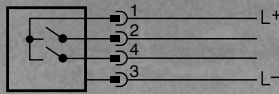

FS 111 / FS 115 – NPN

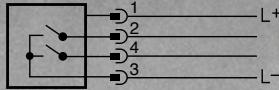

FS 110/FS 111/FS 115 PNP/NPN

- PIN 1 – Supply voltage +24 V
- PIN 2 – PNP/NPN contact of the flow switch point (FS 111 only) / / temp. (FS 115 only)
- PIN 3 – supply voltage GND
- PIN 4 – PNP/NPN contact of the flow switch point

FS 120 – PNP

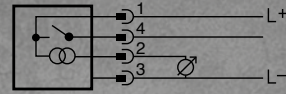

FS 120 – NPN

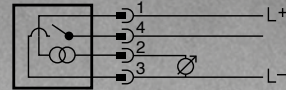

FS 120

PNP/NPN

- PIN 1 – Supply voltage +24 V
- PIN 2 – 4–20 mA output
- PIN 3 – Supply voltage GND
- PIN 4 – PNP/NPN contact switch point

PRODUCT ORDER CODE

FSxxx/Ax/Bx/Cx/Dx/Ex/Fx(m)

FS (Flowswitch)

- 110... one N.O. contact
- 111... two N.O. contacts
- 115... N.O. contact + temperature monitoring
- 120... N.O. contact + 4...20 mA
- DNV... marina approval

A (Operating contact type)

- A1... SSR passive (FS110 only)
- A2... transistor PNP
- A3... transistor NPN

B (Sensor length)

- B1... 65 mm
- B2... 125 mm
- B3... 175 mm

C (Screwed connection)

- | | | |
|-------------|---------------|----------------------------|
| C1... G1/2" | C3... NPT1/4" | C5... CLAMP DN25 (50.5 mm) |
| C2... G1/4" | C4... M14x1.5 | C6... CLAMP DN50 (64 mm) |

F (Sensor construction)

- F1... compact construction
- F2... remote version (cable length 2, 3, 5, 7, 10, 12, 15, 20 m)

E (Adapter for small sizes)

- E1... without adapter
- E2... DN20
- E3... DN15
- E4... DN10
- E5... DN4.5
- E6... DN2.7

D (M12, 4 pin oposit connector)

- D1... YES
- D2... NO



COMAC CAL s.r.o.

Czech Republic, 735 42 Těrlicko
 phone: +420 608 810 032
 e-mail: obchod@comacal.cz
www.comacal.cz