

FPW 05/10/20

FPW 05/10/20 Series Paddle Wheel Flow Meters

The FPW Series Paddle Wheel Flow Meters, based on the principle of mechanical measurement, are used for measuring the flow of clean fluids within the flow rate range of 0.3...6 m/s.

The actual measurement is implemented by the rotation of the paddle wheel rotor fitted with stainless steel needles picked up by the inductive sensor. Due to the design, in which non-magnetic needles are used, tiny ferrous particles are not built up, long service life and stability of the meter is ensured as a result. Rotational motion speed is directly proportional to the flow rate of the measured fluid. The flow meter output can be connected to the display unit or to various control systems.

The meter's great advantages are undoubtedly its quick and easy installation and low purchase costs in comparison with other measurement principles.

The flow meter is made in three versions:
 FPW 05 – pulse signal (w/o variable constant)
 FPW 10 – pulse (variable constant / adjustable switching contact)
 FPW 20 – pulse (variable constant / adjustable switching contact + 4...20mA)

MAIN BENEFITS

- Quick and easy installation and simple attendance
- All-purpose application (measurement of non-conducting fluids)
- Long-term service life
- Absence of magnets (longer service life)
- "Self-teaching" system for adjustment of the switching point in flow rate monitor mode
- Multiple mounting fittings
- All-purpose connection using a 4-pin M12 connector
- Status display using LEDs
- Low purchase costs



COMAC CAL

TECHNICAL DATA

Power	FPW 05: 9...30 V DC with reverse-polarity protection FPW 10 and FPW 20: 24 V \pm 10 % DC with reverse-polarity protection
Display	2x colour LED (FPW05 – 1x LED)
Power connection	4-pin M12x1 FPW 05: TTL output pulses (3 V max. / I _{out} =5mA max.) FPW 10: PNP active (50mA max.) FPW 20: PNP active (50mA max.)
Pulse outputs	
Current output (FPW 20 only)	4...20mA, active (load 400 Ω max.)
Flow rate range	0.3...6 m/s (according to specific adapter and installation)
Accuracy	1...6 m/s \pm 3 % of measured value 0.3...1 m/s \pm 5 % of measured value
Repeatability	\pm 1 % of full range
Hysteresis	2...8 cm/sec
Control	1 flush button
Temperature of fluid	-10...+80 °C
Ambient temperature	0...+55 °C
Material in contact with fluid	Propeller holder (PVDF), propeller (PEEK), propeller shaft (zirconium ceramics), pin in propeller paddle (SS DIN 1.4115), sealing O-rings (EPDM/NBR)
Maximum pressure	25 bar
Pressure loss	0.5 bar max.
IP code	IP67
Ambient humidity	90 % max.
Size (H x Diameter)	90 x 38.8 mm
Weight	135g

PADDLE WHEEL AND MOTION SENSOR

INDIVIDUAL PARTS OF THE METER

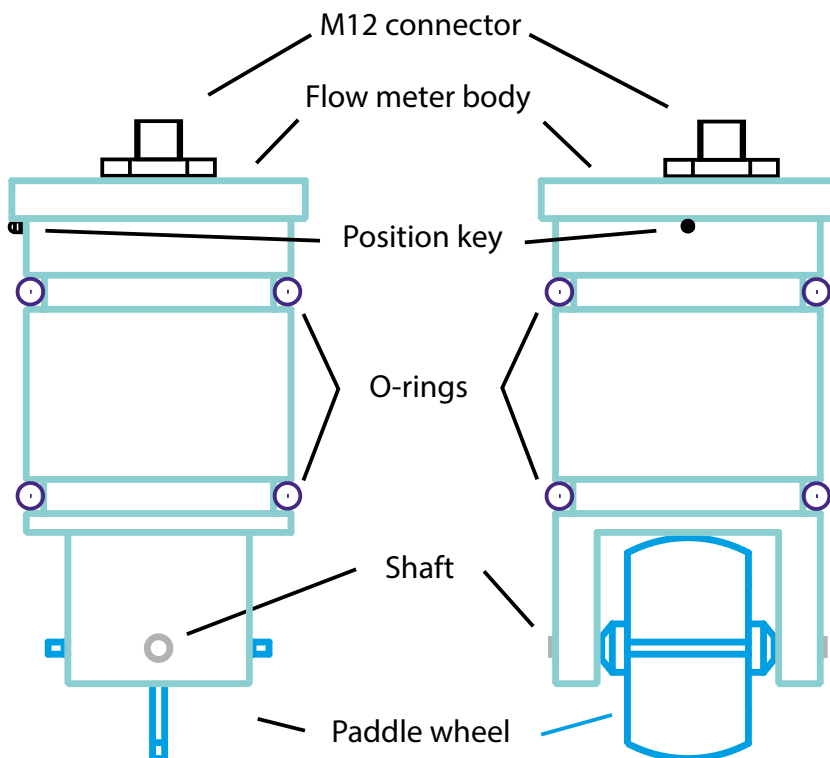

LED DISPLAY

After powering up, the meter performs internal self-diagnostics procedure and LED testing, it consequently switches to measurement mode.

Individual LED operation indication:

Green – POWER (indicates the present supply voltage)

Blue – pulse output function (copying of volumetric pulses at the output) / Flow-Switch function (indication of FlowSwitch contact status)

Orange – flow rate is zero or below the minimum limit

Red – flow rate is above the maximum limit

If none of LEDs is lit or flashing, the meter is most likely disconnected from the supply voltage!!!

BASIC DIMENSIONS

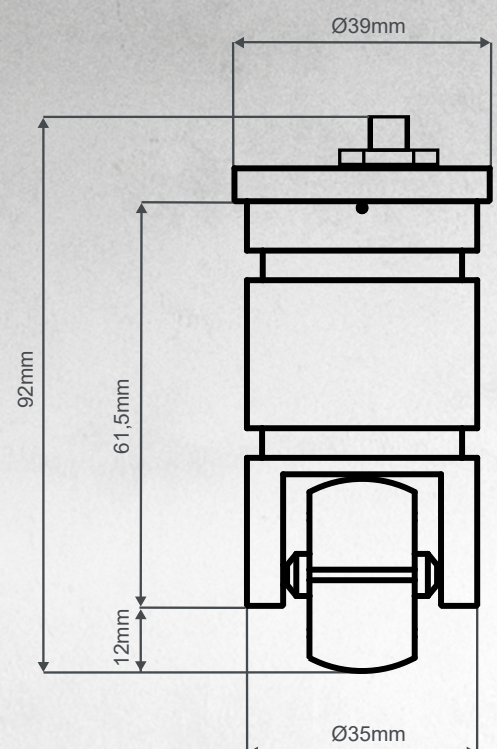

ADDITIONAL ADAPTERS

Various pipe fittings are available. These are designed so as to simplify the installation right into piping using various connection methods (e.g. using external or internal threads, welding, bonding, etc.).

These “in-line” fittings are available in various materials, such as polypropylene, PVC or stainless steel.

Furthermore, you can use a pipe saddle where, after drilling a hole in pipework, the clamp saddle can be put right onto the pipe. Thanks to this, it is not necessary to cut the pipework or weld it.

PIPE SADDLE

To be connected using the pipe saddle in PP design, PN10.



Code	Connection	K-factor
DPPP-10-D63 (B12)	OD 63	According to internal diameter of the piping
DPPP-10-D75 (B13)	OD 75	
DPPP-10-D90 (B14)	OD 90	
DPPP-10-D110 (B15)	OD 110	
DPPP-10-D125 (B16)	OD 125	
DPPP-10-D140 (B17)	OD 140	
DPPP-10-D160 (B18)	OD 160	
DPPP-10-D200 (B19)	OD 200	
DPPP-10-D225 (B120)	OD 225	
DPPP-10-D250 (B121)	OD 250	
DPPP-10-D315 (B122)	OD 315	

PLASTIC T-PIECE

To be connected by bonding in PVC design, PN16.



Code	Connection	Flow rate range	K-factor [imp/l]*
TPVC-16-D40 (B21)	OD 40	2,3 ... 27 m³/h	30
TPVC-16-D50 (B22)	OD 50	3,5 ... 42 m³/h	19
TPVC-16-D63 (B23)	OD 63	5,6 ... 67 m³/h	11.5
TPVC-16-D75 (B24)	OD 75	7,9 ... 95 m³/h	7.5
TPVC-16-D90 (B25)	OD 90	11,5 ... 137 m³/h	5

STAINLESS STEEL THREADED T-PIECE

With G-thread connection in AISI304 design, PN25.



Code	Connection	Flow rate range	K-factor [imp/l]*
TSS304-25-G1/8 (B31)	G 1/8	0,03 ... 0,6 m³/h	1100
TSS304-25-G1/4 (B32)	G 1/4	0,05 ... 1,1 m³/h	662
TSS304-25-G3/8 (B33)	G 3/8	0,09 ... 1,7 m³/h	408
TSS304-25-G1/2 (B34)	G 1/2	0,19 ... 3,8 m³/h	286
TSS304-25-G3/4 (B35)	G 3/4	0,56 ... 6,8 m³/h	149
TSS304-25-G1 (B36)	G 1	0,88 ... 10,6 m³/h	87
TSS304-25-G1 1/4 (B37)	G1 1/4	1,4 ... 17,4 m³/h	42
TSS304-25-G1 1/2 (B38)	G1 1/2	1,8 ... 22 m³/h	37
TSS304-25-G2 (B39)	G 2	4,6 ... 55 m³/h	11

WELDING STAINLESS STEEL T-PIECE

To be connected by welding in AISI304 design, PN25.



Code	Connection	Flow rate range	K-factor [imp/l]*
WTSS304-25-42,4x2 (B41)	42,4x2	2,0 ... 25 m³/h	29
WTSS304-25-48,3x2 (B42)	48,3x2	2,7 ... 33 m³/h	19
WTSS304-25-60,3x2 (B43)	60,3x2	4,6 ... 55 m³/h	11
WTSS304-25-76,1x2 (B44)	76,1x2	7,3 ... 88 m³/h	8
WTSS304-25-88,9x2 (B45)	88,9x2	10,2 ... 120 m³/h	5.5
WTSS304-25-114,3x2 (B46)	114,3x2	17,0 ... 205 m³/h	3.5
WTSS304-25-139,7x2 (B47)	139,7x2	26,0 ... 313 m³/h	2.2
WTSS304-25-168,3x2 (B48)	168,3x2	38,0 ... 458 m³/h	1.5

STAINLESS STEEL WELDING ADAPTER

To be connected by welding in AISI304 design, PN25.



Code	Connection	Flow rate range	K-factor [imp/l]
WSS304-25-D44 (B51)	pipe ID ≥ 48,3	According to internal diameter of the piping	

TABLE OF K-FACTOR VALUES FOR MOST COMMONLY USED PIPE DIMENSIONS

Pipe dimension	Internal diameter ID	Flow rate range	K-factor [imp/l]*
48,3x2	44,3	2,7...33 m³/h	24,8
53x1,5	50,0	3,5...42 m³/h	19,5
60,3x2	56,3	4,5...53 m³/h	11,0
76,1x2	72,1	7,5...88 m³/h	8,0
84x2	80,0	9...108 m³/h	6,6
88,9x2	84,9	10...122 m³/h	5,5
108x4	100,0	14...170 m³/h	3,9
114,3x2	110,3	17...206 m³/h	3,5
139,7x2	135,7	26...312 m³/h	2,2
168,3x2	164,3	38...458 m³/h	1,5
219,1x2	215,1	65...784 m³/h	0,9

ID = internal diameter of pipe
OD = external diameter of pipe

If the internal diameter of pipe is beyond the presented table, the K-factor is then given by the conversion formula:

$$*K\text{-faktor}_{\text{new}} = (K_{\text{TABLE}} \times ID_{\text{TABLE}}^2) / ID_{\text{NEW}}^2$$

ID_{TABLE} the nearest internal diameter is selected from the table for the pipe used

K_{TABLE} is the K-factor from the table corresponding to ID_{TABLE} used

ID_{NEW} is the internal diameter of the tube used for installation

* All K-factor values are applicable to 25 °C water. For FPW10 and FPW20 versions, the K-factors may vary, depending on the pulse constant setting of the meter (dividing ratio). All the indicated dimensions are given in millimetres.

WIRING

M12 connector wiring

The meter is equipped with a standard 4-pin M12x1 connector.



Note: In FPW 05 version, it is typically wired using a 2m long 3-core PVC cable. The eventual M12 connector is wired in the same manner as in the case of FPW10 where pin 4 is TTL output.

FPW 05 TTL

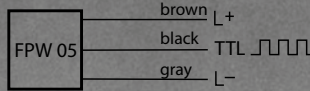

Brown (PIN1) – supply voltage +9...30 V
Black (PIN4) – TTL output pulses (max. 3 V/ 5mA)
Gray (PIN3) – supply voltage GND

FPW 10 – PNP active

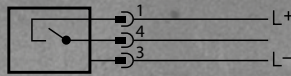

PIN 1 – supply voltage +24V
PIN 3 – supply voltage GND
PIN 4 – PNP contact for pulse/switching points

FPW 20 – PNP active

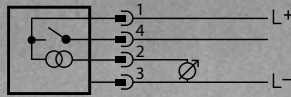

PIN 1 – supply voltage +24 V
PIN 2 – 4...20 mA output
PIN 3 – supply voltage GND
PIN 4 – PNP contact for pulse/switching points

DISPLAY UNIT

The paddle wheel flow meter assembly can be equipped with a local CC100 display unit. It excels in simple attendance and installation by screwing onto M12x1 (4-pin) connector placed on the measuring FPW unit.

The display shows the value indicated by the current output of the measuring device, either directly in mA, or by a value converted into flow rate (m³/h) or flow speed (m/s) according to set quantity units and appropriate 4 and 20 mA limits.

Besides the input connector, the CC100 unit is equipped also with the M12x1 (4-pin) output connector intended for connecting the power supply and current loop to a higher-level system. The connector wiring diagram is identical to that of the meter itself and so the unit forms only an insertion counterpart to the existing measuring circuit without any other necessary modifications.



SUMMARY OF SPARE PARTS

Replacable part	Part number
1) O-rings (EPDM)	FPW-RK1.1
O-rings (NBR)	FPW-RK1.2
2) Paddle wheel (PEEK)	FPW-RK2
3) Paddle wheel shaft (zirconium ceramics)	FPW-RK3.2
4) Union nut (DIN 1.4401)	FPW-RK4

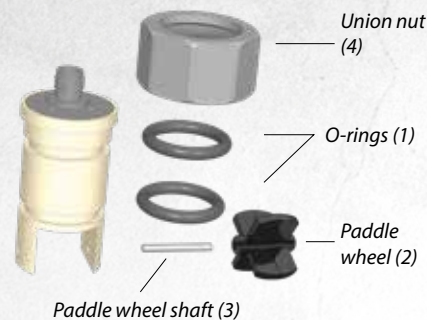

ORDERING CODE

FPW 05/10/20	FPWxx/Ax/Bxx
<p>FPW (paddle wheel flow meter) 05... pulse output 10... pulse / switching contact 20... pulse / switching contact + 4...20m</p> <p>A (oposit connector) A1... M12x1, 4-pin A2... NO A3... 2m long cable 3x0.2 mm2 (FPW05 only)</p>	<p>B (pipe adapter)* B01... without adapter B02... threaded spacer for adapter (SS304) B03... threaded spacer for adapter (PVC)</p> <p>Pipe saddle in PP (PN10) B11... DPPP-10-D50 B12... DPPP-10-D63 B13... DPPP-10-D75 B14... DPPP-10-D90 B15... DPPP-10-D110 B16... DPPP-10-D125 B17... DPPP-10-D140 B18... DPPP-10-D160</p> <p>Plastic T-piece in PVC (PN16) B21... TPVC-16-D40 (2.3...27m³/h) B22... TPVC-16-D50 (3.5...42m³/h) B23... TPVC-16-D63 (5.6...67m³/h) B24... TPVC-16-D75 (7.9...95m³/h) B25... TPVC-16-D90 (11.5...137m³/h)</p> <p>Welding adapter SS304 (PN25) B51... WSS304-25-DN44</p> <p>Threaded T-piece SS304 (PN25) B31... TSS304-25-G1/8 (0.03...0.6m³/h) B32... TSS304-25-G1/4 (0.05...1.1m³/h) B33... TSS304-25-G3/8 (0.09...1.7m³/h) B34... TSS304-25-G1/2 (0.19...3.8m³/h) B35... TSS304-25-G3/4 (0.56...6.8m³/h) B36... TSS304-25-G1 (0.88...10.6m³/h) B37... TSS304-25-G1 1/4 (1.4...17.4m³/h) B38... TSS304-25-G1 1/2 (1.8...22m³/h)</p> <p>Welding T-piece SS304 (PN25) B41... WTSS304-25-42.4x2 (2...25m³/h) B42... WTSS304-25-48.3x2 (2.7...33m³/h) B43... WTSS304-25-60.3x2 (4.6...55m³/h) B44... WTSS304-25-76.1x2 (7.3...88m³/h) B45... WTSS304-25-88.9x2 (10.2...120m³/h) B46... WTSS304-25-114.3x2 (17...205m³/h) B47... WTSS304-25-139.7x2 (26...313m³/h)</p>

* For the correct function of the meter we recommend to order also suitable adapter.

COMAC CAL s.r.o.

Czech Republic, 735 42 Těrlíčko
phone: +420 608 810 032
e-mail: info@comacal.com

www.comacal.com

